

CLEAR HEIGHT OF SIGN (C)

RURAL (⑧)	5'
URBAN	7'
FREEWAY	7'

NOTE: SIGNS SHALL NORMALLY BE ERECTED SO THAT THE SIGN FACE IS TRULY VERTICAL AND AT 93° AWAY FROM THE CENTER OF THE LANE WHICH THE SIGN SERVES AND THE DIRECTION OF TRAVEL. WHERE LANES DIVIDE OR ARE ON CURVES, SIGN FACES SHALL BE ORIENTED SO AS TO BE MOST EFFECTIVE BOTH DAY AND NIGHT AND TO AVOID THE POSSIBILITY OF SPECULAR REFLECTION.

LEGEND

W-HHEIGHT OF SIGN FACE
L-LENGTH OF SIGN FACE
R-RADIUS OF BORDER
E-HEIGHT OF AUXILIARY EXTRUDED PANELS
H-HHEIGHT OF SIGN SUPPORT
C-CLEAR HEIGHT TO BOTTOM OF SIGN

AUXILIARY SUPPORTS
L 3" X 3" X 1/4"
(ASTM A36 STEEL)
OR L 3" X 3" X 3/16"
(A6061-T6)

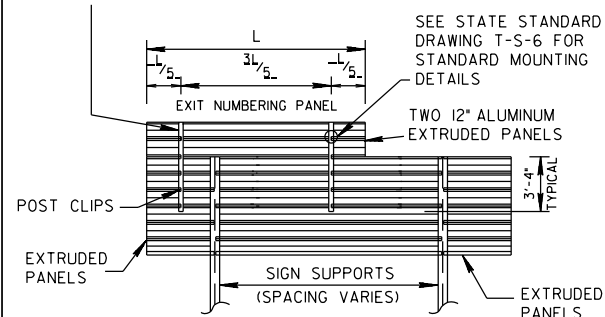

ITEM NO. 713-17.02, INSTALL AUXILIARY SUPPORT FOR EXIT NUMBER PANEL PER EACH (INCLUDES THE COST OF AUXILIARY SUPPORTS AND POST CLIPS).

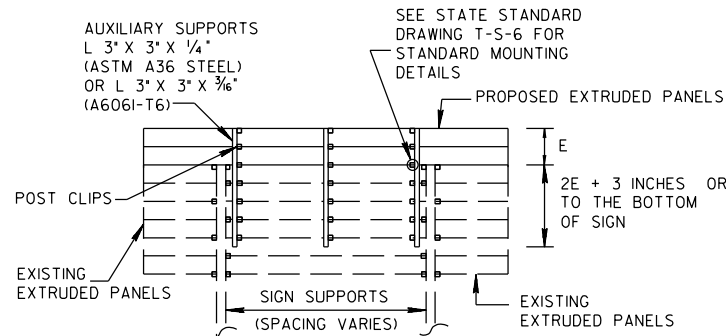

ITEM NO. 713-17.03, INSTALL AUXILIARY SUPPORT ON EXISTING SIGN PER EACH (INCLUDES THE COST OF AUXILIARY SUPPORTS AND POST CLIPS).

GENERAL NOTES

- (A) THE LAYOUTS SHOWN ON THIS PAGE ARE TYPICAL FOR ALL SIGNS ERECTED ON THE FREEWAY SYSTEM AND WITHIN THEIR RESPECTIVE INTERCHANGE AREAS, UNLESS OTHERWISE SPECIFIED IN THE ROADWAY PLANS FOR A SPECIFIC PROJECT.
- (B) ALL SIGNS SHALL BE ERECTED SO THAT THE INSIDE EDGE OF THE PROPOSED SIGN OR ITS ASSEMBLY IS A MINIMUM OF SIX FEET BEYOND THE EDGE OF PAVED SHOULDER OR TWO FEET FROM THE BACK FACE OF THE CURB.
- (C) ALL DIRECTIONAL SIGNS ON THE FREEWAY SYSTEM SHALL BE ERECTED SO THAT BOTTOM OF THE SIGN ASSEMBLY IS SEVEN FEET ABOVE THE EDGE OF PAVED SHOULDER.
- (D) WHEN AN AUXILIARY SIGN IS MOUNTED BELOW THE MAJOR SIGN, THE MAJOR SIGN OR ITS ASSEMBLY SHALL BE ERECTED AT LEAST EIGHT FEET ABOVE THE EDGE OF PAVED SHOULDER AND THE AUXILIARY SIGN SHALL BE ERECTED AT LEAST FIVE FEET ABOVE THE EDGE OF PAVED SHOULDER.
- (E) ALL SIGNS MOUNTED IN URBAN AREAS OR OTHERWISE MOUNTED ADJACENT TO A SIDEWALK SHALL BE A MINIMUM 7 FEET OF CLEAR HEIGHT IN RURAL AREAS WITHOUT SIDEWALK THE MINIMUM CLEAR HEIGHT MAY BE 5 FEET.
- (F) THE CLEAR HEIGHT SHALL BE MEASURED VERTICAL TO THE TOP OF THE SIDEWALK OR, IN THE ABSENCE OF SIDEWALK, MINIMUM OF FIVE FEET ABOVE THE EDGE OF PAVED SHOULDER.
- (G) SEE SECTIONS 2A.18 THROUGH 2A.23 OF THE MUTCD FOR ADDITIONAL INFORMATION.
- (H) SIGN SUPPORTS INSTALLED WITHIN THE CLEAR ZONE SHALL BE BENDAWAY, HAVE A BREAKAWAY SIGN HARDWARE (PER OPL) OR BE SHIELDED BY BARRIER.

FOOTNOTES

- ① SEE SIGN SCHEDULE SHEET IN THE PLANS FOR DIMENSIONS E, L, H, H1, H2, H3, R, AND W.
- ② SEE SIGN SCHEDULE SHEET FOR WIDTH OF BORDER.
- ③ THIS DIMENSION SHALL BE A MINIMUM OF SEVEN FEET SIX INCHES WHEN USING POST SIZE OF W6 X 15 OR LARGER.
- ④ MIN DISTANCE OF FOUR FEET IS TO BE USED BEHIND GUARDRAIL.
- ⑤ DISTANCE OF TWENTY FEET IS DESIRABLE ON FREEWAYS AND EXPRESSWAYS.
- ⑥ DISTANCE OF TWO FEET MINIMUM IS TO BE USED ON URBAN STREETS WITH CURB AND GUTTER SECTIONS.
- ⑦ ANGLE OF REFLECTORIZED SIGN TO APPROACHING TRAFFIC DETAIL DOES NOT APPLY WHEN PROPOSED SIGNS ARE SET BACK THIRTY FEET OR MORE. SIGNS ON TANGENTS THAT ARE SET BACK THIRTY FEET OR MORE FROM THE EDGE OF PAVEMENT SHALL BE ORIENTED AT NINETY DEGREES.
- ⑧ IF SIGN IS PLACED ADJACENT TO SIDEWALK USE URBAN CLEAR HEIGHT.

MINOR REVISION -- FHWA APPROVAL NOT REQUIRED.

STATE OF TENNESSEE
DEPARTMENT OF TRANSPORTATION

STANDARD
LAYOUT
GROUND MOUNTED
SIGNS

1-19-96 I-S-9